

GUI BASED FUZZY LOGIC CONTROL SYSTEM

M. Saleem Khan, M. T. Mushtaq*, T. Syed, S. Yasmeen

Department of Computer Science, GC University Lahore

*School of Science and Technology, UMT Lahore

Corresponding Author: M. Saleem Khan, mshkgcu@yahoo.com

ABSTRACT: The work presented in this paper addresses a generalized graphic user interface(GUI) based Fuzzy Logic Control System(FLCS) to design, edit and execute control system. The proposed system is a user friendly and easy to implement. It helps the user to create a fuzzy logic system in simple steps, inserting the names and membership functions details of all inputs and outputs defining the rule base for FLCS. Detailed structure of the system and design of modules, fuzzifier, inference engine, rule base and defuzzifier were discussed. The results of proposed model were compared with the results of MATLAB Simulink. This research work proposed to develop a novel control system to create and succeed FLCS in few steps efficiently.

Keyword: GUI, FLC, Fuzzifier, Defuzzifier, Rule base, Inference Engine.

INTRODUCTION

Lotfi A. Zadeh proposed the Fuzzy logic in 1965. Fuzzy logic is based on multi-valued logic. This logic defines intermediate values in formal evaluation as true/false, hot/cold, good/bad, yes/no and high/low etc. Fuzzy systems are the substitutes to traditional design of membership and logic that has its start in early Greek philosophy. Fuzzy Logic was introduced as a useful tool for driving system, control, weather forecasting, household and entertainment electronics, expert system and complex industrial mechanism. In last few decades, a lot of work was done in the industrial control domain using fuzzy logic. Solanano S. S. *et al.* [1] mentioned program and design of electronic remote controls with the help of Fuzzy logic using storage space based structure made up of memory space components. Mohammad Y. Hassan *et al.* [2] proposed the design of PID based Fuzzy Logic (FL) controller on field programmable gate array (FPGA) tool. He also proposed fuzzy inference rules along with efficient selection of rules procedure for the management of heat variety for expert programs based heaters. Homaifar A. *et al.* [3] explained the concurrent design of rule sets and MF for FC with the help of inherited algorithms for a specific set of environment. Poorani S. *et al.* [4] suggested FLC for DC motor control for electric vehicles based on FPGA. JyhShing Roger Jang *et al.* [5] explained the concepts of the fuzzy logic control and modeling, method of fuzzy reasoning, fuzzification, defuzzification, for multiple and single rule along with single and multiple antecedents. Mamdani, Tsukamoto, Sugeno, proposed partition style for neuro fuzzy and fuzzy models. They explain their structures with the help of examples. Kim J. H. [6] implemented the FLC for the refrigerator for industrial use to control the distribution of refrigerant for multi type AC. Wang L.X. *et al.* [7] explained the technique for developing fuzzy rules from numeric data. Hollstein T. *et al.* (1996) [8] explained that the performance of fuzzy logic system will be better if they will implement on the hardware as compared to their performance when they implement in software on microcontrollers. They discussed the hardware structure of three different systems and provide computer aided design (CAD) packages for FCS. Chang Jian *et al.* [9] proposed the new hardware design for fuzzy controller (FC) and presented a new technique to create rules of FLC using neural networks and fuzzy set. Fuzzy logic system for temperature control was designed with the help of FPGA. Bin-Da Liu *et al.* [10] proposed a tree based algorithm for the development of FLC. Cirstea M.N. *et al.* [11] implemented

and designed an intelligent control for model power generator and convertor system. Poplawski, M. *et al.* [12] proposed FPGA based FLC architecture for wheel chair. ShuoShen *et al.* [13] suggested a technique to find out the centre of the location by keeping the track of moving targets in wireless sensor networks. Roushan, R.T. *et al.* [14] proposed the implementation of FPGA based fuel control system using. Fujii, Wataru *et al.* [15] proposed FPGA based hardware control module for the design of electronic applications and proposed a decentralized, independent management system for single phase uninterruptible power supply inverter. Yasin M. *et al.* [16] developed Fuzzy Logic Control Systems-FLCS of temperature control for industrial use with Field programmable gate array. The results of simulation display design were examined successfully. In all cases of design, implementation and development, pre-qualified techniques of systems required to know that how best judge requirements were needed using graphic user interfaces. In this paper, structures of fuzzy logic control system along with the detail of main Window/Menu of GUI Based Fuzzy Logic Tool are discussed.

MATERIALS AND METHODS

BASIC STRUCTURE OF FUZZY LOGIC CONTROL SYSTEM:

Fuzzy Logic based decision mechanism uses linguistic variables and can have more than two values [0, 1] in interval. They did not do the strict binary decision. The Fig.1 shows the block diagram of fuzzy logic Controller (FLC). FLC consists of four parts rule base, fuzzifier, defuzzifier and inference engine. For every input has its own fuzzifier and for outputs have individual defuzzifier FLCs has one inference engine and one rule base.

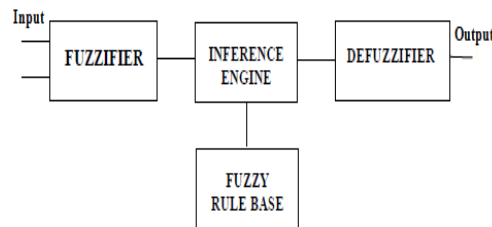

Figure1: Structure for FLCS

Fuzzifier

Fuzzifier is used to convert the input crisp value into the linguistic fuzzy values. The output of fuzzier are linguistic values of fuzzy set. Each fuzzifier consists on subtractor , region comparator, multiplier and divider. Fuzzifier accepts the 0-5V input values and multiplier converts it into the crisp values of given range. Then the crisp values are compared with the given region values with the help of comparator and decides the respective region with the help of input variable. Sub- tractorhelps to find the difference of crisp values from the final values of the selected region. Divider takes the results from subtractor and divide it to map theinput values. Another subtractor is used to find the second value of the other fuzzy set. It is done by subtracting the first fuzzy set value from 1. It must remembered that at least two linguistic values are generated from one crisp value [17].

The Fig.2 shows The block diagram of fuzzifier is shown in Fig.2 and internal design of a fuzzifier is shown in Fig.3.

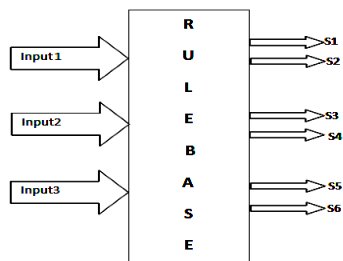

Figure 2: Fuzzifier Block Diagram

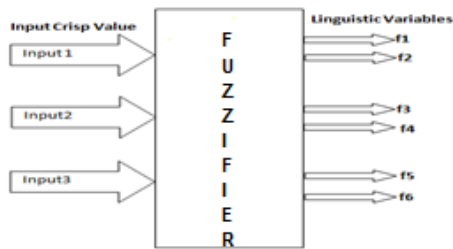

Figure 3: Structure of Fuzzifier

Rule Base

The crisp input values are received by rule base receiver and then these values are checked according to the defined rules of the system. The output singleton value for each output variable is returned if they satisfy the defined system rule. In the present case, the three crisp values are accepted from three inputs by rule selector. Rule base returns The output singleton value is returned from Rule base. Eight rules are required for three input variables in order to find the output singleton value from S1, S2, S3, S4, S5, S6, S7, and S8 in the region of each variable. The Block diagram of rule base is shown in Fig.4

Defuzzifier

The linguistic fuzzy values are converted into output crisp value by defuzzifier. It accepts singleton values from the rule base and the input values from the inference engine. It takes multiple of R and Singleton values and divide it with the help of sum of R values (Fasil Bin Farukh S. et al. 2011) [18], Khan M.S.et al.2010) [19]. Fig.6 shows the block diagram of defuzzifier. The design of defuzzifier is shown in and Fig.7.

Inference Engine

The inference engine plays a vital role in the performance and execution of the FLCs. Two inputs values from each fuzzifier is required. Then the min-max operation was done on received inputs by inference engine and R output values were obtained. The min-max operation apply min-AND operation on each received input. The minimum values were returned as a result of min-AND operation. The Block diagram for the structure interference engine is shown in Fig. 5 below.

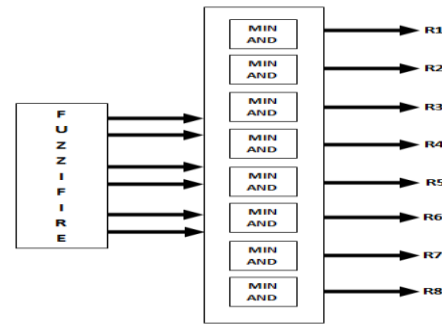

Figure 4: Blockdiagram of Rule Base

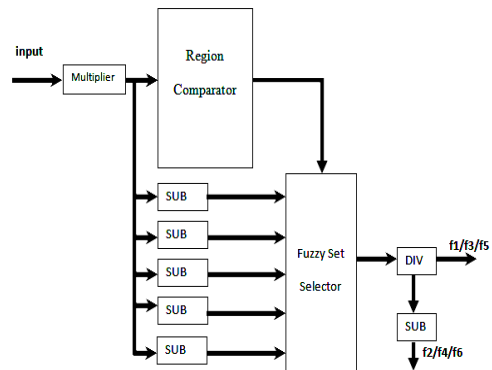

Figure 5: Structure of Inference Engine

STRUCTURE OF PROPOSED GUI BASED FUZZY LOGIC CONTROL SYSTEM:

The Fuzzy inference systems (within the structure) is created and edited with the help of the GUI Based Fuzzy Logic Tool software which contains collection of functions. It is based on graphical user interface (GUI) which can helps to accomplish work. The 5 primary functions were in GUI based Fuzzy too for editing, executing and building fuzzy control systems. The values were used by the users for Inputs and output values of FLC, Rule base, Inference Engine and Execution of FLS. Fig. 8 represents the main window of suggested software design.

Inputs of GUI Based FLC

Input variables were dealt with Inputs values of FLC. Users had authority to enter the names of input variables and variable associated with membership functions. 6 membership functions were defined for 3 variables. Users entered the heap value, starting value and final/ending values of the membership function. The window for the Input of FLC is shown in Fig 9. The window inquire the entrance of the six membership functions and the name of three variables and their details (heap value, starting value and final value) as given below.

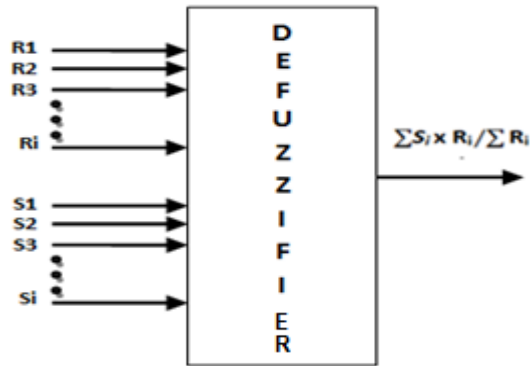

Figure 6: Block diagram of Defuzzifier

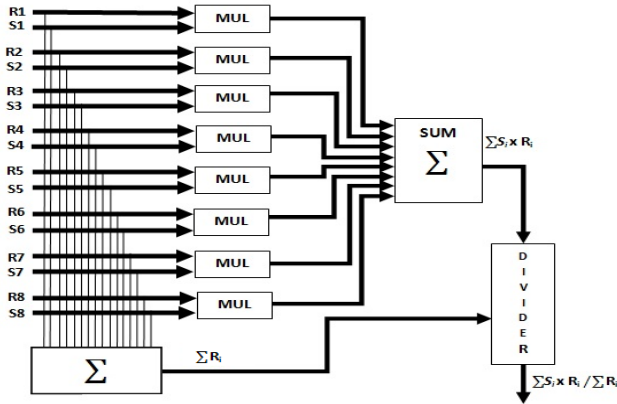

Figure 7. Block diagram of Defuzzifier Design

Temperature, Plant processing time (PPT) and Plant selection (PS) output variables were used.

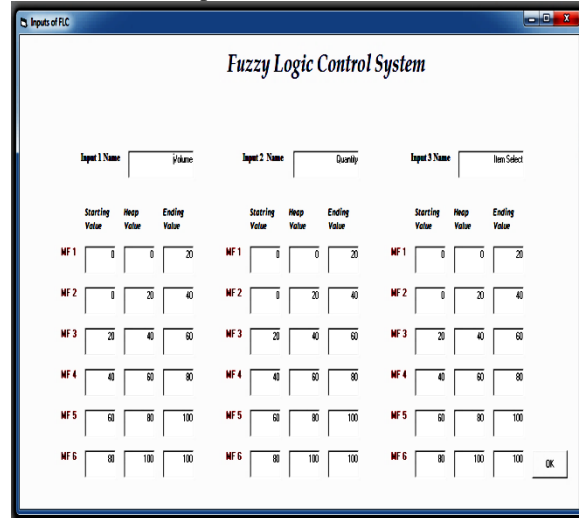

Figure 9. Inputs for FLC

Table 1: Membership Functions for the Input Variables

MF No	Range of MF	Heap	Volume	Quantity	Item Selection	Region
1	0-20	0	Very Small	Very Low	Very Low	1
2	0-40	20	Just Small	Just Low	Just Low	1.2
3	20-60	40	Just Medium	Just Medium	Just Medium	2.3
4	40-80	60	Above Medium	Above Medium	Above Medium	3.4
5	60-100	80	Just Large	Just High	Just High	4.5
6	80-100	100	Very large	Very High	Very High	5

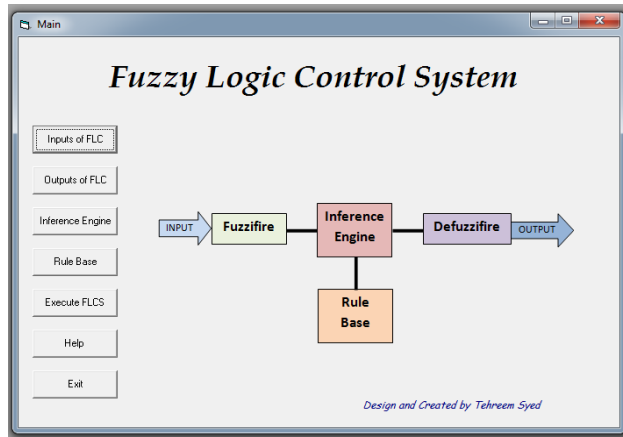

Figure 8. Main Window/Menu of GUI Based FL Tool

The names of variables and the membership functions were defined for testing of Volume, Quantity and selected Items. Table 1 represents the defined MF for each input variable.

GUI based FLC Outputs

Outputs of FLC were used to define the fuzzy output variables. In the present research work, 6 output variables were defined for each and every variable. Users had the authority to enter the names and membership functions of each variable. The 6 membership functions were defined for each and every variable. User entered the heap value, starting value and final/ending value of the membership function. The output window for FLC is shown in Fig 10. In the present experiment Grind rotating time (GRT), Grind rotating speed (GRS), Heating cooling time (HCT), Heating cooling (HC)

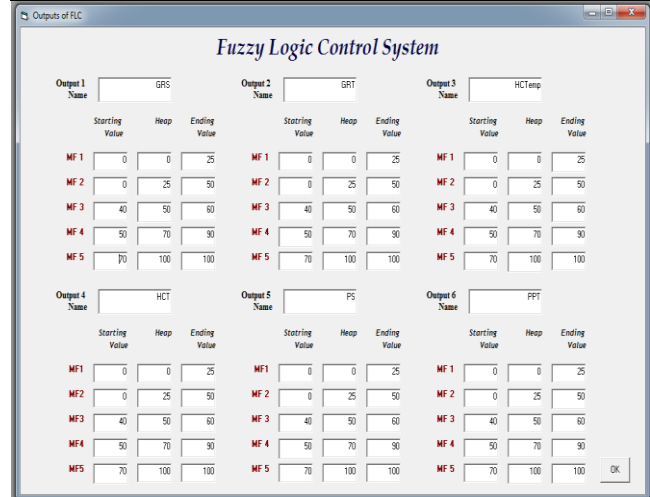

Figure 10: Outputs for FLC

GUI Based Inference Engine of FLC

Inference engine gets three values, one from each fuzzifire out of eight values. First value was obtained from f1 or f2 which are input one, Second value was obtained either from f3 or f4 which are fuzzy set of second input and the third value was obtained from f5 or f6 which are the fuzzy set of third input. Inference engine applied ANded min operator on these values and returned minimum value. Inference engine's window is shown in Fig.11

Table 2: Membership Functions for Output Variables

MF No	Range of MF	Heap	Grind Rotating motor speed	Grind Rotate Time	Heating Cooling Temp	Heating cooling Time	Plant selection	Plant Processing Time
MF1	0-5	0	Stop	No	Stop	No	No	No
MF 2	0-50	25	Low	Small	Low	Small	Small	Small
MF3	40-60	50	Medium	Medium	Medium	Medium	Medium	Medium
MF 4	50-90	70	Fast	Long	High	Long	High	Long
MF 5	70-100	100	Very Fast	Very Long	Very High	Very Long	Very High	Very Long

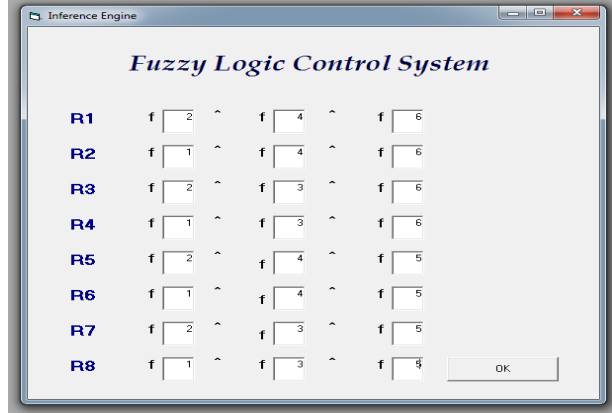

Figure 11: Inference Engine’s window for FLC

GUI Based Rule Base for Fuzzy Logic Controller (FLC)

GUI rule base takes 9 values for each rule, 3 from input and 6 from output. Rule base defined the behaviour of the overall system. For eight defined rules it needs to enter the eight values. The output of the system is always defined on the basis of these rules. The singleton value of each output is calculated on the basis of these values. The rule base is shown in Fig.12 and applied rules are represented in Table 3

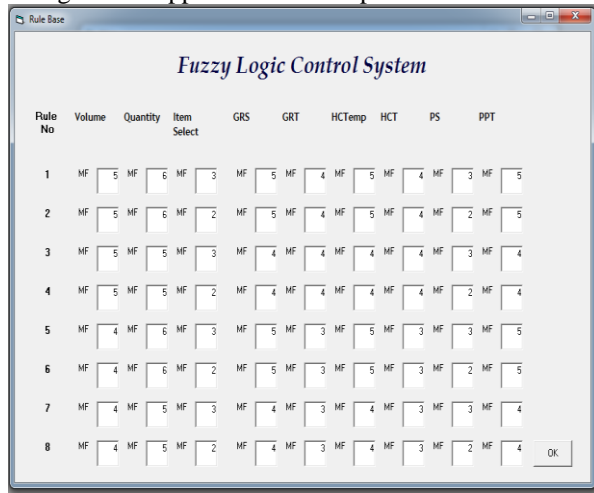

Figure 12: Rule Base of FLC

Table 3: Applied Rules of FLC

Rule #	Volume	Quantity	Item Selection	GRS	GRT	HC Temp	HCT	PS	PPT
1	MF5	MF6	MF3	MF5	MF4	MF5	MF4	MF3	MF5
2	MF5	MF6	MF2	MF5	MF4	MF5	MF4	MF2	MF5
3	MF5	MF5	MF3	MF4	MF4	MF4	MF4	MF3	MF4
4	MF5	MF5	MF2	MF4	MF4	MF4	MF4	MF2	MF4
5	MF6	MF6	MF3	MF5	MF5	MF5	MF5	MF3	MF5
6	MF6	MF6	MF2	MF5	MF5	MF5	MF5	MF2	MF5
7	MF6	MF5	MF3	MF4	MF5	MF4	MF5	MF3	MF4
8	MF6	MF5	MF2	MF4	MF5	MF4	MF5	MF2	MF4

GUI for Execution of FLC

For the execution of FLC, the values of all three input variables between 0-5 were entered. It was shown in Fig 13.

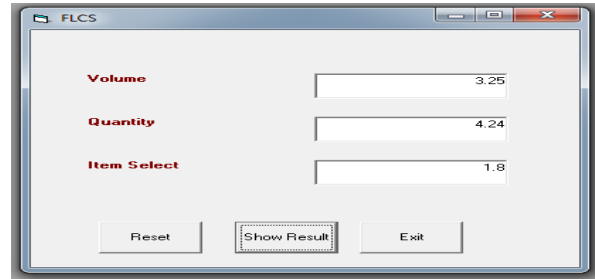

Figure 13: Executed FLC

The display results of the outputs are shown in Fig. 14. It gives the results of all the user defined functions for the FLC (fuzzifire for each input, inference engine and defuzzifires) and the results are displayed in the result window.

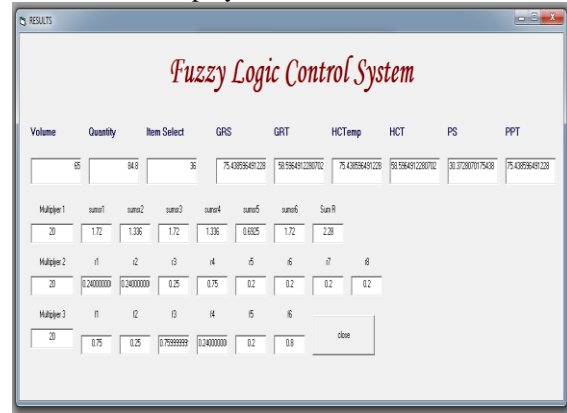

Figure 14: Result Window

Table 4 shows the results of FLC on different input values.

Table 4: The result of FLC on different input values.

No	Volume	Quantity	Item select	GRS	GRT	HC Temp	HC Time	Plant Select	Plant Time
1	40	60	20	70	50	70	50	25	70
2	60	80	30	70	60	70	60	25	70
3	64	85	32	75.6	56.5	75.6	56.5	29.3	75.6
4	70	84	36	74.5	58.1	74.5	58.1	32.9	74.5
5	76	90	24	69	45.9	69	45.9	29.5	69
6	78	98	50	66.8	41.8	66.8	41.8	34.3	66.9
7	70	80	38	64.1	62.4	64.1	62.4	33.3	64.1
8	65.2	91.2	31.2	79.38	55.95	79.38	55.95	29.45	79.38
9	80	93	37	88.46	65.38	88.46	65.38	25	88.46
10	84	92	39.2	78.20	62.82	78.20	62.82	28.84	78.2

Table 5 shows the comparison between the simulation results and the proposed GUI based system. The accuracy of the developed system is displayed in table 5. The time delayed in the system is responsible for the Error rate.

Table 5: Comparison between simulation results and GUI Based Systems

Results	GRS	GRT	HC Temp	HC Time	Plant Select	Plant Time
Design Values	75.65	58.69	75.65	58.69	30.43	75.65
MATLAB Values	73.5	60.1	73.5	60.1	37.2	73.5
% Error	2.9	2.3	2.9	2.3	18.1	3.9

Table 5: Shows Comparison Between Simulated Results And

Designed Results

CONCLUSION AND FUTURE WORK

The main objective of the present research work was to design and provide the GUI based software tool for fuzzy logic control (FLC) system. The main idea was to provide an easy to design, implement and edit facility to user. The proposed design helped to get an accurate result for the required fuzzy control (FLC) system. The results were obtained in few steps with the help of present user friendly environment.

The proposed system supports three inputs and six outputs. In future work, the system can be generalized for inputs and outputs. The user has options for editing the number of inputs and outputs of his own choice.

REFERENCES

- [1] Solanano, S.S. et al., Design and Application of Digital Fuzzy Controllers, Sixth IEEE International Conference on Fuzzy System (FUZZ-IEEE-97). Vol.2: 869-874 (1997).
- [2] Hassan M.Y. et al., Design of FPGA Based PID-like Fuzzy Controller for Industrial Applications, IAENG, IJCS. 34(2): (2005)
- [3] Homaifa A. et al., Simultaneous Design of Membership Functions and rule sets for Fuzzy Controllers using Genetic Algorithms. Fuzzy System, IEEE Transactions: 129-139 (1995).
- [4] Poorani, S. et al., FPGA-Based Fuzzy Logic Controller for Electric Vehicle, Journal of The Institution of Engineers, Singapore: 45(5), (2005)
- [5] JyhShing Roger Jang et al., Neuro-fuzzy Modeling and Control, IEEE Proc.378-406, 83(3): 378-406 (1995)
- [6] Kim J.H., et al., An Application of Fuzzy Logic to Control the Conditioner, Fuzzy Systems Conference Proceedings FUZZ-IEEE, Vol.3: 1350 – 1354(1999)
- [7] Wang L.X. et al., Generating Fuzzy Rules by Learning from Examples, IEEE Transactions, Vol.2: 1414-1427 (1992)
- [8] Hollstein T. et al., Computer- Aided Design of Fuzzy Systems, Based on Generic VHDL Specifications, IEEE Transactions on Fuzzy Systems,4(4): 403-409, (1996)
- [9] Chang Jian, Fuzzy Controller Hardware Design and Implementation, ASIC 2nd International Conference: 321-324 (1996)
- [10] Bin-Da Liu et al., Design and Implementation of the Tree- Based Fuzzy Logic Controller, IEEE Transactions on Systems, Man and Cybernetics,27(3): 475-487(1997)
- [11] Cirstea M. N. et al., Intelligent Fuzzy Logic Controller for Power Generation Systems, IEEE International Conference on Electrical Machines and Drives: 321-324, (1999)
- [12] Poplawski M. et al., Controller in FPGA Circuit for Guiding Electric Wheelchair, IEEE Conference on Human System Interactions: 405-408(2008).
- [13] ShuoShen et al., Comparison of Three Kalman Filters for an Indoor Passive Tracking System, IEEE International Conference on Electro/Information Technology: 284- 289 (2007)
- [14] Roushan, R.T. et al., FPGA implementation of an automobile pollution control system using a MEMS accelerometer, IEEE International Conference on Industrial Technology: 1607-1612, (2006).
- [15] Fujii et al., Construction of FPGA Based Hardware Controller for Autonomous Decentralized Control for UPS Application, IEEE 12th International Conference on Power Electronics and Motion Control: 846-851(2006)
- [16] Yasin M. et al., The Hardware Design of Temperature Controller Based on Fuzzy Logic for Industrial Application Employing FPGA, ICM 2004 Proceedings. The 16th International Conference on Microelectronics ICM: 157 – 160 (2004)
- [17] Khan M.S. et al., Multi-Dimensional Supervisory Fuzzy Logic Time Control DEV Processing System for Industrial Applications, Proceedings of the International Multi Conference of Engineers and Computer Sciences IMECS, Vol II (2009)
- [18] Fazil Bin Farukh S. et al., A New Approach of Syrup Manufacturing Using Fuzzy Time Control Discrete Event System, Yanbu Journal of Engineering and Science Vol.2 (2011)
- [19] Khan M.S. et al., Design of Liquids Mixing Control System using Fuzzy Time Control Discrete Event Model for Industrial Applications, World Academy of Science, Engineering and Technology WASET: 48 (2010)